

1. APPLICABILITY

This specification is applicable to DiVolta rechargeable sealed NiMH cylindrical cell, DN-1200AAHT.

2. GENERAL

2.01	Type designation	:	DN-1200AAHT									
2.02	Nominal voltage	:	1.2V									
2.03	Shape and dimension	:	Refer to Drawing 1									
2.04	Typical weight	:	24g									
2.05	Typical Capacity	:	1250mAh after standard charge and 0,2C discharge									
2.06	Nominal Capacity	:	1200mAh									
2.07	Minimum Capacity	:	1150mAh									
2.08	Standard charge	:	0.1C for 14hrs. to 16 hrs.									
2.09	Fast charge	:	Up to 360mA for 4 hours									
2.10	Trickle charge	:	0.03C to 0.07C									
2.11	Operating Temperature	:	<table border="1"><tr><td>Charging:</td><td>Standard:</td><td>0°C to 70°C</td></tr><tr><td></td><td>Fast:</td><td>10°C to 45°C</td></tr><tr><td>Discharging:</td><td></td><td>-10°C to 65°C</td></tr></table>	Charging:	Standard:	0°C to 70°C		Fast:	10°C to 45°C	Discharging:		-10°C to 65°C
Charging:	Standard:	0°C to 70°C										
	Fast:	10°C to 45°C										
Discharging:		-10°C to 65°C										
2.12	Storage Temperature	:	<table border="1"><tr><td>< 1 year:</td><td>-20°C to 35°C</td></tr><tr><td>< 3 months:</td><td>-20°C to 45°C</td></tr></table>	< 1 year:	-20°C to 35°C	< 3 months:	-20°C to 45°C					
< 1 year:	-20°C to 35°C											
< 3 months:	-20°C to 45°C											
2.13	Maximum discharge current	:	2400mA									
2.14	Discharge cut-off Voltage	:	1.0V/cell									

3. APPEARANCE

There shall be no dirt, scratch or deformation detrimental to practical service in appearance.

4. TEST METHOD

4.1	Test temperature	:	20 ± 5 °C
	Relative Humidity	:	65 ± 20 %
	Time frame	:	Within one month of delivery

5. Performance

5.1 Standard Charge

Standard charge means charging the cell with a current of 0.1C for 14hrs. to 16hrs.

5.2 Capacity

The initial capacity is the discharge capacity of the cell measured with a discharging current of 0.2C within one hour after the standard charge. Up to three cycles are allowed in order to reach the minimum capacity.

5.3 Open circuit Voltage

The open circuit Voltage is above 1.25V within one hour after standard charge

5.4 High rate capacity

The high rate capacity is measured with a discharging current of 1C to a Voltage of 0.95V after standard charge.

High rate capacity >960mAh

5.5 Charge retention

After standard charge and a storage time of 28 days at ambient temperature, the capacity is measured using standard discharge.

Capacity > 780mAh

5.6 IEC cycle life

According IEC285 (1993) 4.4.1, the cycle life is 500 cycles.

5.7 Trickle Charging Life

For trickle charge under room temperature, the cell should typically last for 4-6years.

For trickle charge at 40 °C, the cell should typically last for 2 - 4 years

For trickle charge at 65 °C, the cell should typically last for 1 - 2 years

5.8 Leakage

After charging at 0.1C and storage for 14 days at room temperature, no leakage nor deformation

5.9 Short Circuit

After standard charge, the cell is short circuited for one hour with the following wire:

0.75mm² x 20mm

Leakage and deformation may occur, however, no explosion is allowed.

5.10 Safety Device Operation

This means the safety device of the cell will allow the escape of gas if the internal pressure exceeds a critical value.

The cell shall be forced discharged at an ambient temperature of $20^{\circ}\text{C} \pm 5^{\circ}\text{C}$ at a constant current of 0.2C to a final voltage of 0 V. The current shall then be increased to 1C and maintained in direction at the same ambient temperature of $20^{\circ}\text{C} \pm 5^{\circ}\text{C}$ for 60 min. Leakage and deformation may occur, however, no explosion is allowed.

5.11 Vibration Test

This means the endurance of the cell against vibrations

Conditions:	Amplitude:	1.5mm
	Vibration:	3000CPM
	Time:	60min.
Criteria:	No major mechanical damage nor functional loss.	

5.12 Drop Test

This means the endurance of the cell against drop

Conditions:	Height:	1m
	Direction:	Not specified
	Surface:	Wooden board, 5cm thick
	Number of tests:	Three times
Criteria:	No major mechanical damage nor functional loss.	

5.13 Overcharging

The overcharge capacity is the discharge capacity of the cell measured with a discharge current of 0.2C within one hour after charging for 28 days at a current of 0.1C..

Overcharge capacity $\geq 1100\text{mAh}$. No leakage.

6. Warranty

As long as the cell is treated in accordance with this product specification, one year limited warranty against workmanship and material defects is given.

7. Drawings and Dimensions

DN-1200AHT (High Temperature) Cell

Sealed rechargeable Ni-MH cylindrical cell

Dimensions (with tube)

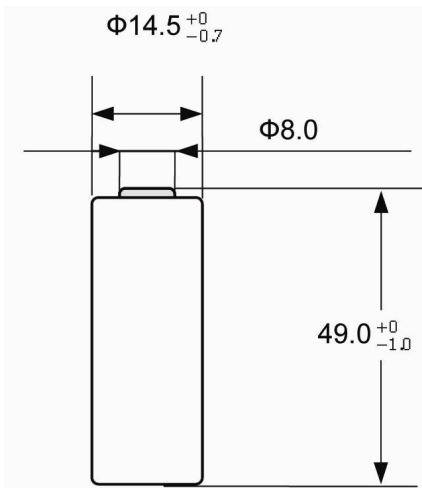

Typical characteristics:

Standard charge characteristics

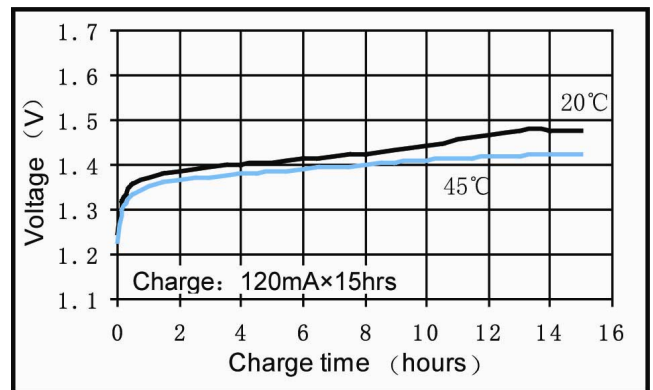

Trickle charge characteristics

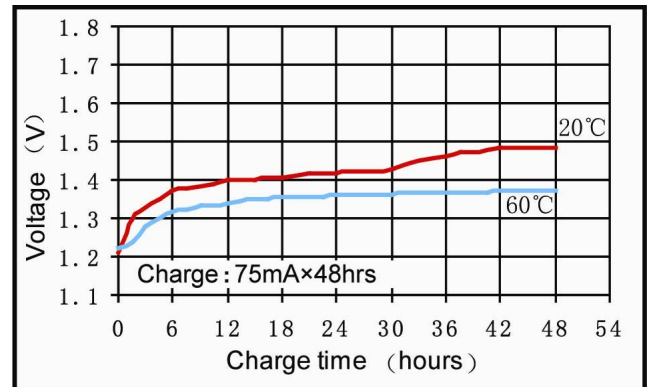

Specifications

Nominal Voltage		1.2V	
0.2C Discharge Capacity*	Typical**	1250mAh	
	Nominal	1200mAh	
	Minimum	1100mAh	
Weight**		24g	
Charge	Standard	120mA for 14 to 16hrs.	
	Fast	Up to 360mA for 4 hours	
Life Expectancy	500 cycles		
Trickle Charge Life Expectancy	room temp.	-typically	4 - 6yrs.
	At 40 °C	-typically	2 - 4 yrs
	At 65 °C	-typically	1 - 2 yrs
Operating Temperature	Charge	Standard	0°C to 70°C
		Fast	10°C to 45°C
	Discharge		-10°C to 75°C
	Storage	< 1 year	-20°C to 35°C
< 3 months		-20°C to 45°C	

Discharge characteristics

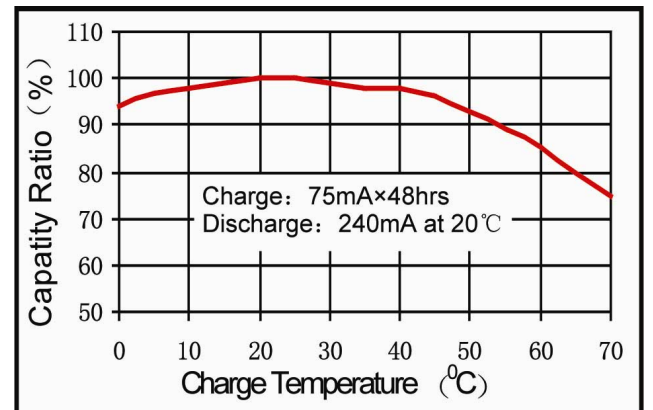

* Capacity is tested after charging 0.1C for 14 to 16 hours.

** Typical capacity and weight are for reference